

**SOCIETY for the PRESERVATION of
BEERS from the WOOD**
(founded 1963)

PINT in HAND

Number 97

February 2006



The Royal Oak, Southwark (with the Editor outside for a change!)

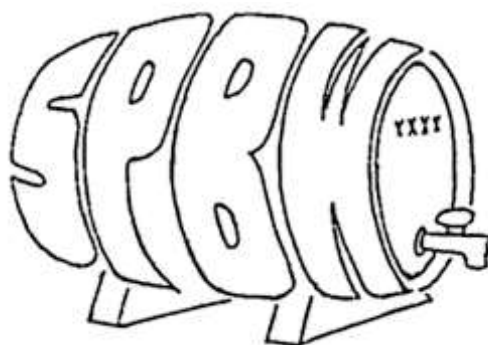

PINT in HAND

- ***Pint in Hand*** is published quarterly, in February, May, August and November. It is issued to all subscribing members and affiliated branches of SPBW.
- All members are invited to contribute articles for publication on beer-related subjects. Contributions for the February 2006 issue should reach the Editor by **20 April**.
- The Editor or the National Executive Committee of SPBW does not necessarily share opinions expressed in *Pint in Hand*.

© Copyright Society for the Preservation of Beers from the Wood

* * * * *

Editorial address

Roger Jacobson

email editor@spbw.com

Membership Secretary

Roger West, Four Winds, 70 Chalfont Road, Seer Green, Beaconsfield, Buckinghamshire HP9 2QP; email membership@spbw.com

Branch Liaison

Bill English, email beeel@myway.com

Products (until mid-March)

Peter Willett

email peterwillettuk@yahoo.com

General Secretary

John Rooth

email john.rooth@gfk.com

National Chairman

Chris Callow

email chris@callow.com

* * * * *

Website: <http://www.spbw.com>.

On-line forum: <http://www.spbw.com/bb>

* * * * *

Anyone reading this that is not already a member of SPBW might like to know that annual membership costs only £5 (£6 non-UK). For information about SPBW together with a membership form, please send a stamped addressed envelope to the National Membership Secretary as above.

OPENING TIME

Just a couple of issues ago I expressed my concerns over the future of many of our surviving independent family brewers. With Ridley's classic brewery in the Essex countryside destined to become residential premises, Gales of Horndean have followed them by taking the money and selling out to a predator. Fullers, now the proud owner of the Hampshire business, may not be Greene King or W & D, but it seems highly doubtful that the Gales brewery has a long term future. The same may be said of Gales' beer brands; other than HSB, they've largely failed to make an impression outside Gales' traditional trading area. It seems that in practice, Fullers have gained an additional 100 or so outlets for London Pride. Of course, I'd love to be proved wrong.

In the last issue I looked back at the 1974 CAMRA Good Beer Guide. Out of the independent breweries listed in that edition, no less than 37 have closed, almost all after having been taken over by predators. Remember also that Bateman and McMullen would also have gone to the great hop back in the sky had some of the family shareholders had their way. Down the road from Fullers, there remains a question mark over the future of Youngs Ram Brewery. If they are eventually obliged to relocate or simply stop brewing I think I can comfortably (albeit with disappointment) predict what the company's option will be.

All the time, the Big 2 not-so-regionals are getting bigger, as are the major pub groups. This means a reduced choice for the consumer. There may well be an increasing number of micro-brewers but no matter how good their beers may be, it's not much use if they can't find outlets for them. How many genuine free houses are there these days? And how many micros can afford to buy their own pubs?

Happy to say, Harveys of Lewes, remains independent and in operation and their one London pub, the Royal Oak in Southwark graces the front cover yet again (the first pub to achieve this accolade three times). There are no apologies for this, but a few good reasons for this: it's my favourite pub and it's once again been voted the SPBW's best pub in London (see page 4); and I've recently indulged myself in a digital camera in an attempt to improve the illustrations in PiH (copying them from websites has its limitations) and this is one of the first examples of my work. However, I don't want anyone to think that this magazine is in any way London-oriented; I do my best to reflect that we are a national organisation. I hope to be doing plenty of drinking and snapping outside the capital in the coming months, but I'd welcome photographic contributions from you (emailed in jpeg format ideally). If this illustrates a written article so much the better! This is the 25th year of Pint in Hand and it's rather disconcerting to note that I've been responsible for every issue. I've thought twice about volunteering for anything ever since!

Roger Jacobson

NATIONAL EXECUTIVE COMMITTEE

The SPBW National Executive Committee holds its regular meetings on the second Monday of each month, hopefully starting at 7 pm. Our current venue is the Royal Oak, Tabard Street, London SE1. This top-class Harveys pub should need no introduction in these pages.

These are strictly business meetings, but they are kept as brief as necessary. All members are welcome to attend, particularly representatives from branches.

LONDON PUB OF THE YEAR

The SPBW London Pub of 2006 winner is the ***Royal Oak***, Tabard Street, London SE1. There were also honourable mentions for the Harp (Trafalgar Square) and Robin Hood & Little John, Bexleyheath.

The Royal Oak also won the award in 2004 and is also the regular venue for monthly meetings of the NEC and its AGM. In other words we like the pub a lot and it's mutual: the Royal Oak is very SPBW-friendly. I'm sure that many of you are familiar with this excellent Harveys house and if not you are recommended to rectify this omission at the earliest opportunity. Suffice to say it's a friendly 2-room pub tucked away in the back streets off Borough High Street, serving the full range of Harvey's fine ales, invariably in prime condition thanks to Frank's dedicated cellarmanship. John's cooking provides excellent solid refreshment.

The presentation to Frank was made on 2 February. He was given a framed, multicoloured certificate (thanks to John O'Connor and Bill Stansfield). There was a healthy gathering of SPBW members (including all of Woolwich branch, whose meeting night this was) along with some lucky locals. Sadly, Miles Jenner was unable to represent the brewery but there was a free pint all round plus a generous and tasty buffet.

Thanks to Bill English for organising the judging and to his fellow judges who undertook the great sacrifice of visiting some fine pubs across London.

NATIONAL WEEKEND

The 2005 event in Nottingham and Derby was a great success and the details are recounted elsewhere in this issue. Thanks to John Rooth for organising. For 2006 we are thinking of the Black Country, *provisionally* 17 - 19 November. Holdens, Highgate and Sarah Hughes breweries have been sounded out for visits and there are numerous excellent pubs in the area. Keep in touch with the SPBW website or any of the NEC members listed on page 2 for more details; these will of course appear in the next issue.

ANNUAL GENERAL MEETING

The 2006 AGM of the SPBW National Executive Committee will be held on **Monday 13 March** at the **Royal Oak**, 44 Tabard Street, Southwark, London SE1. The meeting will be in the upstairs room and will start on the very dot of 7 pm. All SPBW members are invited to attend. It should be a short and informal business meeting and an excuse for SPBW members to get together for socialising and sampling the splendid range of Harveys beers. We expect to provide some solid refreshments as well.

The Royal Oak is just off Borough High Street, between Long Lane and Great Dover Street. Nearest tube station is Borough (Northern line) and London Bridge is about half a mile north. I'm sure that many of you are already familiar with this award-winning pub. As this it's now been featured on four of the first five pages of this issue, you should be familiar!

Anyone interested in standing for a post on the NEC should contact John Rooth (details on page 2) well in advance of the AGM. Peter Willett will be standing down as Products Manager and we need a replacement. Should the job interest you, contact John for a job description. Peter is following his predecessor, Dave Brightwell, into retirement in Turkey. We can't guarantee this is a perk of the job. Nevertheless, many thanks to Peter for his great efforts over the last year or so.

BEER & CURRY

If you fancy a break from your healthy lifestyle, the annual B & C event will occur on **Sunday 12 March**. This year we kick off at the Coborn Arms, Coborn Road, off Mile End Road (the Editor's local Young's pub) at noon onwards. At 2 we move to the Black Bull, Whitechapel (via 25 bus) and the Pride of Spitalfields at 4 (but behave yourselves - see PiH 94). Then we'll find a gourmet restaurant on Brick Lane, no doubt picking up some refreshments from an offie en route. It'll be helpful if you can let John Rooth know if you'll be coming along.

PUBLICITY

We have produced a stock of SPBW publicity booklets. In 8-page, PiH-style, these set out some history and general background of the Society, with an application form at the end. The general idea is for these to be placed in worthy pubs so they can be picked up by discerning imbibers. Copies have been sent to the select band of publicans who are SPBW members; if you think you can find a good home for these booklets please let me (Roger) know and I'll send you a bundle. A contribution to the postage would be very welcome: 5 x 2nd class stamps covers the cost of sending 30.

SPBW WEBSITE

As you should all be aware, the SPBW Members Forum is still going strong at www.spbw.com/bb. Mark Hutchison, our webmaster, will always welcome suggestions on how to improve this and our general site; contact him at: marksalehousecom@hotmail.com.

The Bulletin Board is intended as a way for members to exchange information. It's very easy to get involved with and, as with most things, the more the merrier. We are particularly keen to see representatives of branches acting as moderators to help keep their sections up to date.

EMAIL ADDRESSES

If you want to receive up to the minute news about SPBW events, you can get this information in the comfort of your own PC monitor. Send your email address to John Rooth and he will add you to his circulation list. We promise that your email details will only be used for the transmission of SPBW material.

FROM THE ARCHIVES

The cover of the February 1996 issue of PiH announced the closure of the Home and Websters breweries by what is now called Scottish Courage. According to the current Good Beer Guide, beers badged as Websters are still brewed by Burtonwood; surely they can't be as appalling as those insults to the brewer's art that used to emanate from Halifax. Home beers used to be decent enough.

The SPBW had been featured on BBC Radio Cleveland who had a regular feature on small organisations and interviewed then Vice-Chairman Rod Richmond. I'm not aware that any of us ever heard the broadcast interview. Elsewhere in the issue was a report on a device called a Beer Saver which was meant to allow beer left in the pipe to filter back into the cask at the end of a session. Nigel Parsons, our technical wizard, reported that this was, in theory, a good thing, but I don't think that it ever caught on.

Interesting to glance back a further 10 years when PiH still appeared in A4 format, using an electric typewriter, letraset and duplicator. The legendary Maltworm was still contributing a column and I notice that I was also looking after SPBW products. A long time ago!



BILL WADLEY

Bill, a stalwart member of SPBW Special branch in the 1970s and 80s died tragically and suddenly on Boxing Day.

I first met Bill in August 1975 when we were both working at the former MAFF. We shared a number of interests, not the least of which was good beer; Bill soon persuaded me to join CAMRA. I soon latched onto his drinking fraternity and began to visit beer festivals and good pubs in all corners of London and beyond. Some time in 1976 or 77 we began to use the Rose & Crown in Blackfriars regularly and here we encountered members of Special Branch. Bill and I joined the branch and Bill was soon volunteered as the branch's representative at NEC meetings. Bill was Special Branch Chairman 1979 – 81 and held other committee posts as well as being an enthusiastic supporter of branch events. He was a regular winner of the Branch's Fenton trophy darts contests and a mainstay of the branch's sports quiz team that performed wonders in the Sunday People's national knock out competition.

Away from the SPBW Bill was keen on sports, supporting Chelsea FC and Surrey CCC, and once part-owning a couple of greyhounds (one named Kegbuster after Bill Tidy's cartoon character); up to his death he was a regular punter at Folkestone races for several years. As a performer, Bill was a keen and accomplished darts player, skippering the Rose & Crown team to league honours in the mid-80s and later captaining a team at the Wheatsheaf, Borough Market.

Bill was cremated at Norwood Cemetery in January. Before and after the funeral a good crowd of his old friends drank to his memory in the Hope, his former local Youngs pub in West Norwood.

Bill was a generous, honest and good-humoured individual and I am proud to have known him as a friend and drinking companion; he will be missed by everyone who knew him.

R.J



The Sekforde Arms, Clerkenwell. Not one of Bill's old haunts, but it is a Youngs pub!

BRANCHES IN ACTION

Once again, only a few of our branches have contributed to this section. I'm sure these can't be the only active branches, so please keep me informed of what you have been, and will be, up to.

Campden Hill In November a few of us went on a pub-crawl of Kingston, calling in at four pubs including Rick's pub, the Willoughby Arms, which was excellent as usual, on the way. The Canbury Arms is now a gastro pub, but still has some interesting guest beers, including Harvey's and Hogback TEA. Wych Elm is a true local, a welcoming Fullers pub with a log fire. The Park Tavern has a regular rotation of unusual guest beers.

In December 6 Campden Hill members, plus 1 NEC guest had a splendid evening at the Andover arms in Hammersmith. Plenty of Fullers beer and then an excellent 3 course Thai meal in the back room, which we had all to ourselves. All very reasonably priced (10% discount) and a free round of drinks from the hosts.

Future events include: The Keith Hudson darts competition on 16 February at the Sekforde Arms 8.00; 20 February Mongolian barbecue, Maiden Lane Covent Garden, meet at the Harp Chandos Place from 7.00. 27 February – Not Burns night, with haggis prepared by Alasdair Boyd, at the Wenlock Arms. Meeting wise, we have become nomadic, as we scour West London for a suitable venue, so it is wise to check with a committee member.

Northern Ireland branch has initiated a Pub of the Year award. The King's Head, Lisburn Road, Belfast, is the first winner and the presentation will be made when we can get a time arranged. We hope to get a good lot of publicity for the award and hence the branch. The pub it is owned by the Botinns chain and has been featured in PiHs 43 and 93. It sells mostly Whitewater beers and majors on food, which is very good. More details will follow on the local website - www.spbwni.co.uk.

Ponds will be going back "home" to the Greyhound, Carshalton for their meeting on Monday 20th March. After that the intention is to continue to meet on the third Monday each month, or as near a date as is convenient, either in the Greyhound or other local pubs - hopefully in the summer we'll be a little more adventurous. Best to check with Dave Hamer as to where.

RACS celebrated Burns' Night on 29 January with haggis, neeps, tatties and general north British entertainment. The De Merc choir sang "Toss the pot" (by great demand) among many others choice items. Sunday 19 February looks like being a busy night at the Gate: there'll be a presentation of a charity cheque to Judy and Robert Houghton for the Cystic Fibrosis Trust; the launch of RAC's very own beer brewed by the Sawbridgeworth Brewery and a Valentine's quiz. Sunday 23 April will see a St George's Day bash at The Gate with Morris dancers, Steak & Ale pie and fun and jollity. There'll be the usual trips to breweries and beer festivals.

Special Branch is beginning to build up for our annual gathering on the canals in May. This year we begin near Northwich on the Trent & Mersey

Canal and will be filling publicans' coffers around Cheshire and Manchester.

Wantz had a rare 'AGM' in January. Roger was re-elected as Chairman and Michael took over as Treasurer from the Turkey-bound Peter. On 1 March we make a return visit to the ever-popular Dovetail in Clerkenwell, to satisfy our taste for fine Belgian ales.

West Riding visited the Burton Winter Ales Festival at the end of January. Trips to beer festivals at Fleetwood and Bradford are being lined up in the next couple of months. On 21 April there's a trip to Moorhouses brewery in Burnley.

BOOK REVIEW

The Lost Pubs of Bath

Andrew Swift & Kirsten Elliott

Akeman Press ISBN 0-9546138-4-8 £15.00

This is the last of a trilogy which began with *Bath Pubs*, the history of the city's existing pubs and continued with *Awash With Ale*, the history of drinking in Bath. This final volume tells the story not only of pubs that closed within living memory, but of many that called last orders hundreds of years ago.

The book takes the form of nine 'excursions' covering different areas of the city plus a further chapter covering outlying villages. These take the form of what would have been pub crawls when the pubs were actually in business; a high proportion of the buildings no longer exist. There's also an intriguing list of many of the breweries that have owned pubs in Bath. This includes the Anglo-Bavarian Brewery of Shepton Mallet (last brewed 1939), the English Lager Brewery (went into receivership 1893) and Ruddle's of Bradford on Avon (closed 1924; any relation?)

Getting back to the pubs, there is a remarkable amount of detail given, very effectively illustrated by copious photographs, many of which illustrate how much the mainly Georgian city has been redeveloped. To demonstrate the style taken by the authors, let's look at the account of the Globe in Weston High Street, thought to have been the smallest pub in Bath. First recorded in 1852, the pub was owned by the Smith family for 83 years. By 1944 when Septimus Smith took over, the pub had shrunk to a single bar, a mere three feet wide. Septimus had served on the Western Front and been a noted pugilist but by the time he became landlord of the Globe he had expanded somewhat, eventually reaching 21 stone. Not only was there no room for anyone else behind the bar when he was there, there was no room for a till. He solved this problem by wearing a multi-pocketed apron, each pocket holding coins of a different denomination. The Globe finally closed on 31 March 1966.

If you're interested in old Bath pubs, this superbly researched book will do you nicely. If you can't get to a bookshop in the area, copies can be ordered from Akeman Books at 58 Minster Way, Bath, BA2 6RL; phone 01225 310364, email kirsten@akemanpress.com.

R.J

MEET the BRANCHES

Most social activities in the Society take place within branches so it makes sense to get involved with one. You're sure to get a good welcome and most branches prefer to keep things very informal. Details of our branches are listed below; if there isn't one in your area you are welcome to start one! Bill English, (Branch Liaison Officer, address on page 2), will be pleased to tell you what you need to know. We will be happy to put you in touch with other local members.

One of our regular contributors, Somerset Mark, is interested in getting a branch going. Anyone living within about 50 miles of Bath who would like to get involved, please contact Bill and he'll pass your name on.

BMAD: Meetings held first Thursday of each month at the **Burnt Mill Snooker and Social Club** (CIU affiliated) in Harlow, Essex. Contact Tony Syrett (01279 423174)

CAMPDEN HILL: Meetings held first Monday of each month at the **Hammersmith Ram**, King Street, Hammersmith. Contact John Rooth (see page 2).

CENTRAL LONDON: Meetings held on the 18th of each month mostly in the form of pub evaluation walks - usually in central London. Contact Roger West (see page 2).

CHESAPEAKE BAY: Based in the area around Baltimore, Maryland USA - a great area for microbrews and brewpubs. Contact Dominic Cantalupo, email DominicCantalupo@ChampionRealty.com. Website: www.spbw.org.

CHESHIRE: A bunch of beer lovers mainly around the Crewe/Nantwich area are getting together and we hope they'll decide on a name and get properly set up very soon.

COATE: Meetings held third Friday of each month at the **New Inn**, Coate, near Devizes. Contact Eric Clark (ericclark@aol.com) or email coate@spbw.com.

COMMON: Meetings now held in Reading at the **Retreat**, 8 St Johns Street, every Sunday from 2.30. Contact Peter Smith 01189 670647.

IPSWICH: We hope the branch will finally get up and running in the near future. Contact Phil (01473 644923) or Iain (01473 251586).

KINGSTON: Meetings held first Wednesday of each month in the Willoughby **Arms**, 47 Willoughby Road. Contact Rick at the Willoughby [020 8546 4236]; or our website: www.spbwkingston.co.uk.

MAYDAY (Hastings): Based at the **First In Last Out** brewpub, 14-15 High Street. Contact Helen or Tony Champion at the pub on 01424 425079 for further details.

NORTHERN IRELAND: Contact Mark Hutchinson for details of meetings and events: marksalehousecom@hotmail.com

PONDS: Time and place of meetings varies but usually in Carshalton area. Contact Dave Hamer (020 8395 8716 or email dehamer@tiscali.co.uk .

RACS: The Real Ale Club of Sawbridgeworth meets last Wednesday of each month at The Gate, London Road. Contact Jan Mead (01279 864398) or email meadspanner@aol.com.

SPECIAL: The branch holds annual, week-long gatherings around the inland waterways network. There are also unofficial visits to pubs of renown in London, Cheshire and Shropshire, or wherever we happen to be. Check our website at: www.geocities.com/canalnav/SPBW1.html

WANTZ: Meetings are held third Monday of the month at the **Britannia**, Church Street, Barking (Youngs), starting at around 8 pm. Contact Roger Jacobson (see page 2).

WEST RIDING: Meets on Sunday mornings in various pubs in and around Leeds. Contact Graham Hewitt (0113 2624574; graham-hewitt@tiscali.co.uk) for further details.

WOOLWICH: Meetings held first Thursday of each month in Greenwich or Woolwich or sometimes in central London. Contact Bill Smith (020 8310 5907).

Are the details for your branch correct on these pages? If not please the Editor know before the deadline for the next issue; thanks!

TIED UP IN NOTTS

National Weekend November 2005

National Weekends have been annual SPBW events since 1982 and the latest NW went off every bit as successfully and enjoyably as its predecessors. 20 or so members from around the country descended upon Nottingham and Derby to visit two contrasting breweries and a variety of excellent pubs. Most of us stayed at the Gresham Hotel which had a roof and was close to Nottingham rail station but was otherwise undistinguished (mind you, I had a nice view of the canal from my room.

First official gathering place of the weekend was the **Vat & Fiddle**, just south of Nottingham Rail Station. The pub is part of the Tynemill chain, which is in itself a hearty recommendation. Around 10 beers were on offer, including a few from the Castle Rock brewery next door. The V & F merited a lengthy stay but we needed to be elsewhere for the evening. Next on the agenda was a route march to the city centre and a bus out to Kimberley. We had time for a pint or two in the **Nelson & Railway**, the Hardy & Hanson brewery tap; and a cosy and welcoming establishment. Then it was across the road to the brewery itself. H & H is a good example of a Victorian brewery, using the traditional 'tower' system. Time for a bit of history.

In 1832 Samuel Robinson converted an old bakehouse on the corner of Hardy Street in the mining town of Kimberley into the area's first commercial brewery. In 1846 Stephen Hanson bought a site in Brewery Street almost opposite Samuel's brewery at public auction in 1846 and commissioned the building of his own brewery, which started production the following year. In 1857 two ambitious beer wholesale merchants, William and Thomas Hardy, saw a business opportunity and bought Samuel Robinson's brewery. As their business grew the brothers set their sights on expansion and built a new brewery, which opened in 1861. The two competing breweries operated in friendly rivalry, producing beers from the same excellent brewing water from Holly Well. Both breweries thrived until 1930 when, under increasing pressure from larger brewing companies and lack of male successors to Hardy's Brewery, the two companies combined. Other factors which influenced this decision included the miners' strikes and the need to make best use of the precious brewing water. Today the family influence continues with Chairman, Richard Hanson, being the great grandson of the original founder of the Hansons Brewery. Hardy and Hansons own 250 public houses mostly in the East Midlands, with sites also in North West and Yorkshire, and employs around 1500 people.

Barry, our guide for the evening, is a drayman by trade but H & H encourage their staff to take on these extracurricular responsibilities, making for a more informal and light-hearted approach. But Barry knew his stuff about the history and brewing processes – and he had the key to the hospitality room! Four Kimberley beers were on tap here and we were encouraged to sample at length. Our beer tasting was accompanied by a joke telling session, which I

suspect would not happen at Greene King. We were eventually slung out in time for one or two for the road in the N & R before wending our way back to Nottingham (except for one or two taking advantage of the pub's accommodation.)



Saturday was bright but chilly as we took the train to Derby and taxis out to the Derby Brewing Company (www.derbybrewing.co.uk) in a small industrial estate on the eastern outskirts. The DBC is run and entirely staffed by Trevor Harris and partner, sited in a former paint warehouse. It's basically a large one storey shed with a raised section at one end to create the 'tower' effect. Trevor was formerly the brewer at the Brunswick brewpub close to Derby station before setting up the DBC in 2004. The beer range includes Double Hop (4.4%), Business as Usual (4.4%) and a number of others. Our glasses were kept filled with four of Trevor's brews, which were all very tasty and a generous buffet was also consumed.

The rest of the day was spent in a selection of Derby's many excellent pubs (and a Wetherspoons). Most memorable of these were the **Flower Pot** in King Street with its racks of gravity fed beers in the back room; the **Smithfield**, next to the river Derwent, a two bar establishment with another good selection of ales; and two quite near the station: the aforementioned **Brunswick** is now owned by Everard who provide a few choices alongside several beers brewed on the premises and a few guests. If that doesn't give you enough choice, not far along the road is the **Alexandra**, another Tynemill house albeit with a smaller range than usual on our visit.



We had relatively little time to explore Nottingham's alehouses apart from the Vat & Fiddle but many of us did pop in at **Ye Old Trip to Jerusalem**, which is not too far from the station. The Old Trip sits at the foot of Nottingham Castle and is partly built into the castle rock. It claims to be the oldest inn in England, dating from 1189 but there seems to be some dispute about its antiquity; there

is a theory that it was not built until 500 years later and didn't become an inn until the following century. Inevitably it's something of a tourist haunt but, under Hardy & Hanson's ownership, it retains its character and the beer selection is excellent: the full range of Kimberley brews plus a few guests.

There was another exodus out of town on Sunday morning with Beeston – five miles and one rail stop west of Nottingham – our destination. The **Victoria** in Dovecote Lane was the pub of choice and a most worthy one as well. The pub, a railway hotel of some grandeur, was opened by Ind Coope in June 1899 and is the 3rd 'Victoria' to stand on this site. However, by the late 1980s the Victoria Hotel had fallen on hard times, disposed of by a national brewery and a major pub company, and several prospective buyers had failed to see any great potential for a large Victorian edifice stuck at the end of a cul-de-sac. Then in March 1994 the pub was acquired by Tynemill. By the end of the year the ground floor had been completely refurbished. The landlord, Neil Kelso, is also a Tynemill director and in 2001 he made an amicable agreement with Tynemill and the Victoria now operates under the banner of Hands On Pub Co Ltd. The pub is quite a substantial concern, with three rooms and a large conservatory out the back, where our group took refuge. Another fine selection of beers here, ten or so as I recall, including a few from Castle Rock, and the food was good as well. Despite the pub being situated directly adjacent to Beeston station, access to the pub from the platforms is impossible – you have to leave the station and either go round the back and over the footbridge or take a 360 degree detour. Having said that, plenty of people did find it, since the pub was crowded throughout our extended visit; service was excellent and efficient however. The Victoria offers accommodation as well and another couple of our party took advantage of this facility.

After this we generally wended our ways home at various times via other pubs to end another most enjoyable weekend; thanks to everyone who came along to give good company. I shouldn't need to recommend Hardy & Hanson's beers to you, but do keep a look out for Derby Brewery's beers in the free trade as they are also well worthy of your custom.

R.J

National Weekend: The Minority Report

Dateline: Sunday 20th November 2005

The scheduled trip for today was to 'The Victoria' at Beeston. Dave Laing and I decided on a bit of unilateral (can two people be unilateral?) exploration elsewhere. The Nottingham tram system has produced a nifty little brochure, in conjunction with the local CAMRA Branch, which lists real ale pubs in the vicinity of each tram stop. We decided at random on the **Fox & Crown** at Basford (pronounced 'Baseford' we were told). This proved to be a trip with hidden treasures.

On the way out we passed the magnificent, but sadly silent, Shipstone's brewery and at Basford found another very handsome, well-preserved tower brewery. Research has shown this to have been W.H. Hutchinson & Sons Ltd, founded in 1869, bought out by Home Ales in 1914 and sold to the present owners, Murphy's who supply stuff like pipe cleaning fluids for pubs, in 1918. As members will know, the 'Fox & Crown' is the home of the Alcazar Brewery, which also does Thai food (but not Sunday lunchtimes dammit!). They had two guests and eight of their own beers on. We sampled (between us) Salamander Dreadnought (guest from Blackburn), Nottingham Nog (4.2% - a good basic bitter), and then halves of Mocha Stout (5.0% - worthy of its name), Brush Bitter (4.9% - very bitter), Vixen's Vice (5.2% - a strong, quite malty pale ale) and Windjammer PA (6.0% - pale, light, aromatic and very dangerous).

On the way back we stopped off to have a look at the Shippoes brewery, which is still very well-preserved. We went into the **Horse & Groom** (presumably the old brewery tap), which has been partially modernized for dining but still keeps an old-fashioned side room and windows with the Shipstones star badge. We sampled halves of Burtonwood's Golden Delicious and Bramble Stout, two of five beers on tap, both in good condition.

In the evening Dave and I met up at **The Bell** in the Market Square (according to Tony Robinson's Time Team, older than the 'Trip'). A pint of H & H Mild (almost as good as the brewery's!) and we went on to **The Roebuck** in St James's Street, a new non-smoking Wetherspoon's, for a bite to eat. This had the usual basic beers plus five of the Nottingham Brewery's beers. Having eaten, we shared 4 halves, Rock Bitter (3.8% - good session beer), Legend (4.0% - well-balanced best bitter), Cock & Hoop (4.3% - malty and rounded) and Supreme Bitter (5.2% - very malty and a bit goeey - we left half of it).

Dateline: Monday 21st November 2005

At lunchtime we ate in **Ye Old Trip to Jerusalem** (H & H) and purely in the member's interests you understand, we went into the **Fellowes, Morton & Clayton** brewpub by the canal and had a pint of Josher Bitter (3.5% - a bit insipid) and then headed for the station and the smoke. Altogether a good weekend whichever way you went on Sunday.

Patrick Deller



THE PERFECT PUB PAGE

This bit of PiH is a platform for members to spread the word about the best pubs they have encountered. This issue we pay yet another visit to the west country.

Imagine ... a pub that guarantees the warmest of welcomes and that serves a couple real ales good enough to get it in the Good Beer Guide. Imagine that this pub serves five Belgian beers on draught – and at least thirty more in bottles. Imagine that this pub serves good food, cooked as you want it, and then imagine that they never call time (for those stopping overnight, only, of course) and then let's say that this pub is only a stones throw from a main-line railway station so risking your driving license becomes completely unnecessary ...

Imagine no more – because you've found the ***Old Stagecoach Inn*** at Crewkerne in Somerset! The freehold is owned by Anton Jordi, formerly a bar owner in Ostend, and his partner Deloris Thomas, who originally hails from the Caribbean. She too had her own bar and went to catering school before working in two very busy restaurants. Thus it is that we can experience Belgian nights (complete with the Belgian Beer Ambassador himself, Marc Stroobandt) and even Caribbean nights, so we could be eating chicken waterzooi - or jerk chicken! Eat in the comfy bar or the restaurant but don't get talking to the landlord about motor-bikes unless you *really are* into them yourself (a Belgian bike engine adorns one corner of the bar giving a big clue as to Anton's interests!)

Formerly 'The Queen's Hotel' in times past, here we have a truly cosmopolitan pub in the heart of Somerset, where the broad tones of the locals contrast with the European accents of mine hosts, and where on occasions several languages may be heard in one evening. Your writer has counted eight in total so far, including, would you believe, Afrikaans ...

Don't just take my word that this is a 'must visit'. Take a look at the web-site to see what you're missing <http://www.stagecoach-inn.co.uk/index.htm> (check out that food *and* beer menu!) and then pay a visit the pub to see what you really are missing! Why not even spend a few nights in the West Country with my 'Perfect Pub', and use it as a touring centre? Just don't tell *too* many people about it though, okay...?

So is there a downside to a visit here? Well yes, there is one that I feel I ought to share with you. You see, this is one of those places where the beer fairy is also in residence. Ah! So you haven't experienced the beer fairy? This is what happens. She sees you come into the bar just after six, at opening time, and then twenty minutes later when you look at your watch – it's five minutes to midnight ...

John Penny

As ever, contributions for this page will be very welcome; even more so if accompanied by an illustration!

BOTTLES AND BELLS

Andy's Roving Report

York

Any readers of this periodical who have visited the **Blue Bell** in York may feel that I am babbling when I now mention a beer festival that I attended there on Remembrance Sunday. For the unknowing, this inn is a beautifully preserved piece of Edwardian architecture that is probably the most minute pub in the city, consisting of two small rooms and a corridor. Nonetheless, such an event goes ahead here every November, 2005's being the fourth so far. What makes it possible is the fact that, as the festivities are held on a Sunday and Monday, the licensees can have the road outside (Fossgate) blocked off to traffic. A marquee is erected across the thoroughfare and heaters are dotted tastefully about. Most of the customers will end up outside as the pub itself can get totally packed.

So where do the extra beers go you cry. In the tap room at the front, four or five barrels of fruit/honey beers were racked in the bottom corner; the bar proper was reserved for pale ales or bitters; no less than nine milds, stouts and porters could be found in the small nook at the top right hand side of the corridor. The beers changed rapidly and I have no idea how many actually were on sale over the two day event.

Having made my purchase, I made my way outside to where various ratbags from Leeds had foregathered near one of the heaters. I emphasise near, as one of our number, Martin, had strategically placed himself to soak up most of the warmth, only relinquishing his position when his coat and hair combusted. From the Blue Bell we set off on a pub crawl, taking in the **Last Drop Inn**, **Three Legged Mare** (both York Brewery pubs), and the **White Horse** (Thwaites with Konig Ludwig weisse bier) before the company broke up, with most heading for the railway station. Schenk and myself being Men of Steel, headed for the **Minster Inn** and finally the **Maltings**. In the latter inn we bumped into the landlord of the Station Tavern in Huddersfield who was in town on business. A most enjoyable evening's stroll, but next day I felt I really should get myself sponsored by Anadin.

Stockport

One from over the Pennines now, in the Cheshire town of Stockport. The natives here are fortunate indeed in still having a number of proper pubs and beers that are actually affordable. I need not refer to the **Railway** on Avenue Street where the Porters brewery mild is £1.10 a pint and the Porter costs about 20p more, which is good going for a 5% beer! No, I shall sing the praises of the **Red Bull** at the top end of town on Middle Hillgate. Yea brethren, this is a Tremendously Traditional Tavern, with dark wood panelling and beams. The main bar serves a large tap room which rambles off into nooks and crannies along with a separate snug that can also be reached via the lounge to the right. Unusually nowadays, the lounge has its own bar, dispensing, like the one in the tap room, Robinson's Hatters Mild and Unicorn Best Bitter (or is it Best Bitter?) Anyway, the mild was £1.78 and the Unicorn £1.86. both were in excellent order and I speak as one who is oft disappointed

by 'green' tasting pints of Hatters. It is alleged that the directors of Robbie's Brewery, which is just down the road, bring favoured guests here for a pie and pint. The Red Bull is a reminder of a civilised world and you'd expect to see Kenneth More or John Gregson at the bar. Definitely a must to visit.

Bradford

And now an absolute classic, folks. The **Cock & Bottle** at the junction of Barkerend Road and Shipley/Airedale Road in Bradford, is one of Britain's best pubs, both for state of preservation and the range of beers therein. The miracle is that the pub is here at all, having had a number of owners and even being shut for about 3 years – usually a death sentence these days.

It was built in the 1820s, spreading into an adjacent building about 30 years later: Melbourne brewery of Leeds purchased the business in 1927, being bought out themselves by Tetley in the 1950s. I understand that much of the woodwork and glasswork dates from the early part of the 20th century. Virtually all of this is the genuine material and where it was necessary to replace damaged or broken fittings, no expense was spared to obtain a precise duplicate; there's real workmanship here good people. It is claimed, and reasonably so, that any customer from 60 years ago could walk into the pub and immediately recognise it. As an example, one piece of internal acid-etched glass had been smashed, so the present owners, William Greenwood's brewery (of Bradford) paid a local craftsman to manufacture an exact copy. Ask the bar staff about this and see if you can spot which is the new pane.

There are two entrances to the pub: the one on Airedale/Shipley Road (which is lethal to cross) takes you into the bar area and the multiple snugs. Entering, look straight ahead into the small room directly facing you at the marvellous piece of stained glass, which proclaims the Cock & Bottle to be a Tetley Heritage Inn. Then look up above the doorway at the clock in the magnificent carved cabinet – you won't find this in B & Q,

Other rooms/snugs lead off directly facing the bar; the largest of these has a TV screen and hosts musical extravaganzas, both live and recorded. Elsewhere one will find peace and quiet, as well as a good selection of old photos and an interesting history of the pub and immediate surrounds.

The tap room lies at the other side of the bar proper and is pretty much suited to purists (even though I don't watch telly) and has a solid wood floor which is far preferable to hideous carpets that are sticky enough to have been manufactured by Wrigley's. Notwithstanding the two separate entrances to the C & B there is an internal passageway that links the tap and the rest of the pub.

On the night of the visit described, we had a most informal chat with the Entertainments Manager as well as the landlord himself. They mentioned that a group from Dorset had recently visited the pub, having journeyed all the way north for this specific purpose.

Finally, I must mention the beers. There were 9 on: three from Greenwood's themselves and half a dozen from all over. The Greenwood's Fat Prop Porter is first rate (just in case you haven't tried it yet); in fact all the ales sampled were in top condition, including an amazing Tetley's Imperial (4.6%) which

was £2.00 a pint. The Copper Dragon Black Gold was £1.90 and all the beers listed were cheaper than would be paid in most pubs nowadays. The chances of there being a pub like this near to you are non-existent – visit asap.

And now to bring the reader up to date with a bit of news about pubs mentioned in recent issues of this esteemed quarterly.

The **Hat & Feathers** in Manchester (PiH 94) has been reported as closed by the South Manchester and Stockport CAMRA Magazine *Opening Times*. I rang the pub's phone number and got the recorded message that the number had not been recognised. It seems that the H & F will now be found in the Blue Remembered Hills. A good back street pub bites the dust due to property developers.

In the same issue, I mentioned the **Sands Bar**, also in Manchester. This has been given a lick of paint and otherwise spruced up a bit. A trip of us visited it during C'mas week and were slightly surprised by the new lighting and the fringe across the top of the bar counter. Is the Sands Bar going up market?

The **Baroque** in Leeds (PiH 93) has won no less than two CAMRA awards, plus a most prestigious 'Pub of the Season' presentation from West Riding Branch SPBW. It is also one of Sue's Approved Inns which is high praise indeed. The Baroque has hosted a Wheat Beer Festival as well as an Oktoberfest, with offerings on the handpumps and font as well as in the bottle.

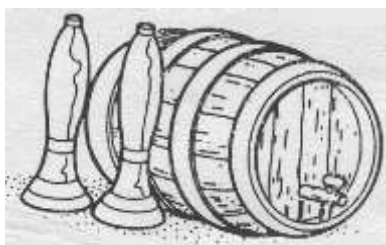

The Last Word – from Cyprus

On holiday in Paphos, Cyprus, early October last year I called into the Old Shack bar hoping to try the real ale version of Moorhouse Pendle Witches Brew brewed on the island and sold in the bar, only to find it is no longer brewed there. I then made a beeline for John Richardson's Monroe's Brewery Bar (formerly First In Last Out) on Konstantias Street. This is now the only place real ale is brewed and sold in Cyprus. I found three real ales on sale all at £1.70 Cyprus (about £2.36 Sterling). Mr President best bitter (just over 4% abv), Boop de Boop (4.5) and Marilyn's BB (5.5) were all found to be in good condition. John, a CAMRA member from Wakefield, brews twice a week a total of 700 pints, all sold in the bar. An Irish stout is brewed for winter and a new beer, to be called Norma Jean, is being brewed (abv not known).

Free tours of the brewery are available, usually on a Thursday or Saturday morning, just ask at the bar. John is supported by his wife Julie and a great team of friendly staff. If you are in Paphos it has to be worth a visit.

Ken Roberts

PRODUCTS

SPBW products currently available are as follows:-

40th Anniversary Tankards

(white bone china with colour motif) £10.00

T-shirts

(printed cask motif on navy/black; M only) now only £3.00

(woven motif on white/yellow/black, L, XL) £9.00

Sweatshirts

(Woven motif on royal blue/burgundy/jade, XL only) £15.00

Polo Shirts

(woven motif on royal blue/burgundy/jade, L, XL) £13.00

Denim Shirts

(Blue, long or short sleeves, L, XL, XXL) £20.00

Fleeces

(Navy, royal blue, bottle green or black, L, XL, XXL) £21.00

Ties

(multiple motif on blue) £6.50

(multiple motif on brown or green) £5.00

Hats

(Acrylic knitted, woven logo on royal blue, black or bottle green; one size only) £5.00

Enamel Badges

(gold motif on black rectangle or brown motif on white oval) £3.00

You can admire our product range on the SPBW website!

- **Please add £3.00 per order to cover postage and packing; if only ordering badges add only £1.00**
- **Please send your orders to: Peter Willett (until mid-March – after that contact one of the people listed on page 2).**
- **Please make cheques payable to SPBW and include a telephone number with your order. Allow up to 28 days for delivery.**

Some back issues of ***Pint in Hand*** are available:- numbers 43; 44; 46-57; 60-62; 68; 70-81; 84-96. These can be obtained from the Editor (address on page 2) in return for fifteen second class stamps to cover postage for the full set).